

Issue Severity:



High: Act immediately



Medium: Bosch Security Systems strongly recommends you take the action(s) described below.



Low: Advisory

Products Affected:

D6412 and D4412 Control Panels with EPROM versions 1.08, 1.10, and 1.11

1.0 Issue

If you have D6412 or D4412 Control Panels with the EPROM versions listed above (refer to *Figure 1* for the version location), pressing the [CMD] key followed by [9] [5] causes a System Fault. The control panel could notify the central station of a system failure, reset the date and time, and fill the Event Log with invalid events.

Pressing [CMD] [9] [5] does not harm the control panel or system in any way. It will continue to operate normally.

Figure 1: EPROM Location and Revision

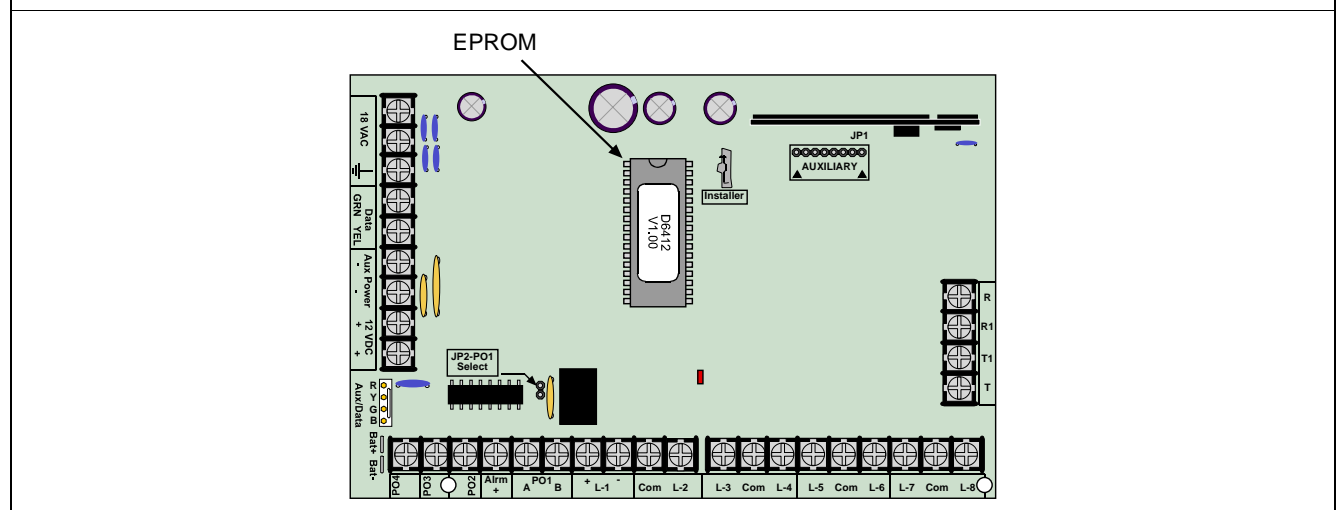

2.0 Resolution

For an immediate solution do not use [CMD] [9] [5], and do not assign passwords that begin with 95.

EPROM version 1.12 corrects this issue. Call Customer Service at (888) 289-0096 and request the appropriate EPROM Upgrade kit at no charge:

- D6412 request P/N: D6499-0112
- D4412 request P/N: D4499-0112

